

## Using the Grand Hammer Tail Arcing Jig ..... ©1998 Bill Spurlock

Unless they are ordered pre-shaped, new replacement hammers need to have their tails arced prior to installation. The tail shape of already-installed hammers can often be improved as well—it is not unusual to find replacement hammers and even factory original actions with poor tail shaping, resulting in poor hammer checking or touchweight problems. This jig allows you to sand a consistent tail arc into hammers whether they are right out of the package or already hung on shanks.

### Achieving proper hammer checking

Ideally, hammers should be able to check  $\frac{5}{8}$ " or closer to the strings without dragging on the backchecks on the way up, should check approximately the same distance from the strings regardless of playing force, should check reliably on a soft blow, and the hammer tails should not wear out the backchecks prematurely. To achieve these goals we need the following:

**1. Correct backcheck height & tail length:** See figure 1. Sometimes backchecks can be raised to improve checking when tails are short, but not if this causes large bass & tenor hammers to bump into the backchecks at rest. Tails can usually be  $\frac{1}{8}$ " to  $\frac{1}{4}$ " longer than original without any problem—in fact extra length will often improve checking and repetition. Just make sure they do not contact the wippen flanges at rest. As a general rule 1" is usually a minimum workable tail length.

**2. Correct tail arc:** See figure 2. For best repetition, we normally adjust the backchecks so the hammers check as high as possible, but a limiting point is reached when the hammer tails drag on the backchecks on the way up (during a hard blow). Notice that as the hammer rises, it follows a 5 1/4" radius (the shank length). At the same time, the backcheck moves in an arc also, bringing it closer to the path of the hammer. Therefore to avoid contact between backcheck and tail, the tail must be arced to a smaller radius than the shank length. If that radius is a combination of the hammer path and the backcheck path, the clearance between the two will remain uniform as the hammer passes on its way up, as shown in the drawings. This radius will be around 2 1/2" to 3", and allows you to set minimal passing clearance because the tail has no humps that have to clear. At the same time, this tail shape will be as straight as possible and thus offers maximum contact area with the backcheck. This improves checking on a soft blow and reduces backcheck wear.

As a rule of thumb, choose a radius more toward 3" if the backchecks are more rounded, if the hammer tails are over 1" long, or if a smaller radius would leave the bottom of the tails too thin. A radius closer to 2 1/2" can be used if the backchecks are flatter, or when tails are shorter and thicker.

**3. Correct backcheck angle:** See figure 1. With the key depressed and the hammer in aftertouch position, extend an imaginary line off the bottom curve of the tail. The backcheck leather should be parallel to that line. This angle should give fairly constant checking distance with varying playing force, as well as max. passing clearance between tail and check.

**4. Backcheck leather and hammer tail surfaces in good condition:** Older backchecks should generally be replaced or recovered during hammer replacement. I prefer replacing with new backchecks and wires. When tail length,

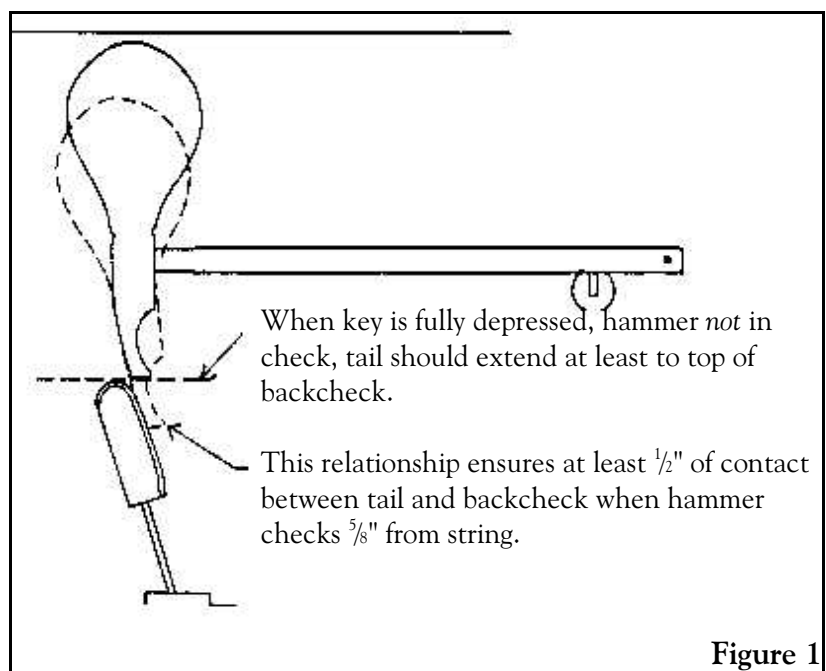
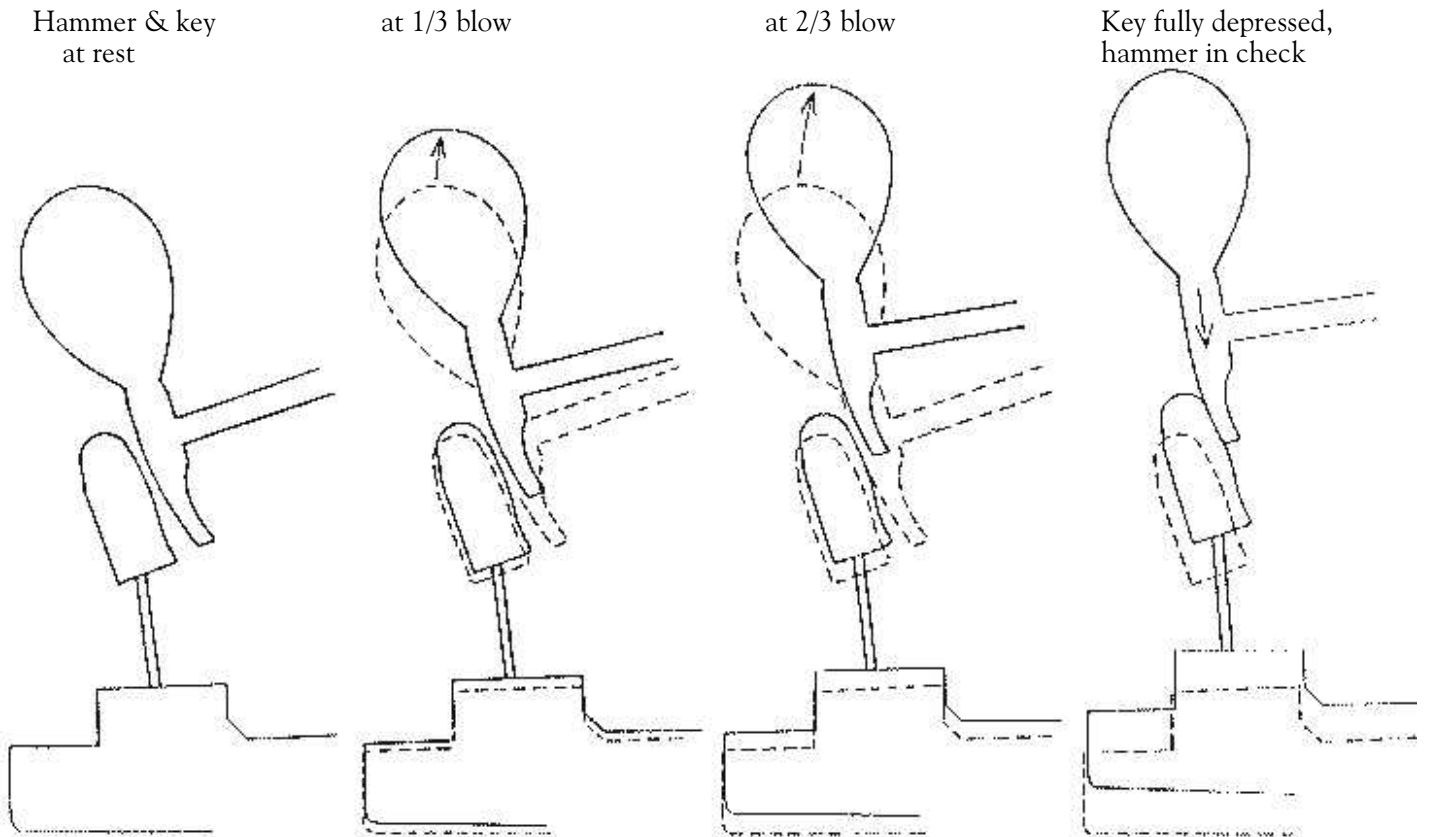

Figure 1

arc, and backcheck angle are correct then wear on backcheck leather is minimal because the contact area is large and the rubbing surfaces are smooth curves. *No "checkering" or extreme roughening of the tails will be necessary to achieve good checking.* Likewise, if tails etc. are *not* right then no amount of tail roughening will really give good results.

**Figure 2:** an action with proper tail curve, tail length, backcheck height, and backcheck angle



*Note that the tail and backcheck pass with even clearance, and wedge tightly together with good contact area when in check*

### **Adjusting and using the arcing jig**

When tapering the sides of new hammers using the Spurlock Tools Tapering Jig, you must taper *before* arcing the tails. For arcing, use either a stationary belt or disc sander *with new coarse paper*, preferably 60 grit, running at a low speed if variable. When using a disc sander, lower the table below center if possible, so that the hammer tail will be on a horizontal with the disc center. Adjust the arcing jig as detailed on the following page.

Once the jig is basically adjusted, test sand sample hammers from both bass and tenor to fine-tune tail thickness and arc. By trial and error, adjust the radius screw and jig base location until both bass and treble sample hammers have as large a sanded area as possible without excessive thinning at the bottom ends of the tails. Depending upon tail length and the existing inside shape of the tails, one brand of hammers may require a slightly different radius than another. Ideally you will be able to sand a continuous arc from the shank down to the end of the tail (although on very angled bass & tenor hammers the sanding will not cover the complete width of the tail until you are down below the shank hole). Once you've chosen a basic radius, you can fine-adjust the lower tail thickness if necessary (using the radius adjusting screw) as you progress through the set.

Assuming accurate boring, your tails should all come out very uniform. The coarse new sandpaper will leave the tails with a good textured surface; together with the right backcheck height and angle, no further roughening of the hammer tails will be needed to ensure reliable checking. The only further tail work needed will be dressing the ends of the shanks after they are trimmed, and very slightly rounding the sharp edge at the bottom of the tails with a hand sanding block. Both these steps are done with the shanks clamped together, as detailed in my publication, "Grand Hammers—boring, tail shaping and installation."

